

# Promotion Stand

**ComLite**

GRAPHICS DISPLAY SYSTEMS

Lightweight plastic, flat pack promotional unit  
Extremely cost effective Includes rigid header panel, shelf and twin supporting poles Supplied with carry bag

## Features & Benefits:

- Lightweight plastic, flat pack promotional unit
- Extremely cost effective
- Includes rigid header panel, shelf and twin supporting poles
- Supplied with carry bag
- Comes with two graphics that are attached via Velcro

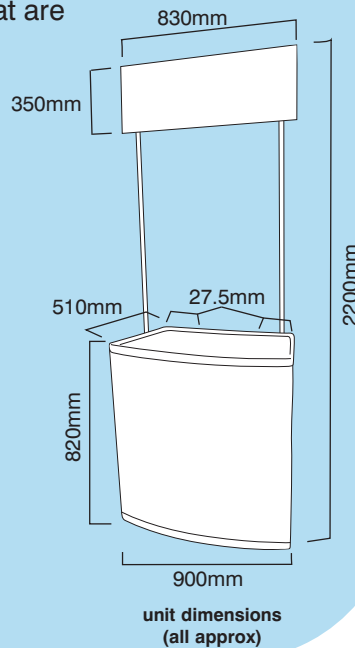

Image demonstrates the location of the graphics

\* illustration only. - Actual unit may differ slightly.

## Hardware Specifications:

Hardware Dimensions (mm)  
2200 (h) x 900 (w) x 510 (d) approx.

Base Dimensions (mm):  
910(h) x 900 (w) x 510 (d) approx.

Weight:

10kg approx (inc carry bag)

## Graphics Specifications:

Recommended graphic dimensions  
See above wrap layout

Header dimensions (mm):  
350(h) x 830(w) approx.

## Additional:

Exclusive to PHASE

Tel: 01773 764288  
[www.phaseprint.com](http://www.phaseprint.com)

